

SeaKing Towfish DST Sidescan Sonar

Features

- Extremely cost effective
- Easy to deploy and recover
- Low power and high data rates
- Compatible with SeaKing product family

Applications

- Coastal surveys
- Military mine counter measures
- Shipwreck location
- Pipeline and route surveys
- River, harbour and canal surveys



The SeaKing Towfish Sonar System is an extremely compact and cost effective, high definition sidescan sonar system. It is designed for a wide range of seabed survey and inspection duties. The 300kHz frequency has a useful range up to 200 metres either side.

The fish combines the very latest Tritech DST (Digital Sonar Technology) electronics with industry leading transducer design and digital CHIRP signal processing techniques to dramatically improve range resolution and generate sonar images of unprecedented clarity.

The sonar 'fish' is designed to be easily deployed by hand with excellent stability under all towing conditions. Fitted with durable polycarbonate stabiliser fins, in the event of ground contact the fins will break away and are retained for recovery by a shock cord line.

The fish has a weak link and safety recovery line. If it hits an obstruction the weak link will part but the 'fish' will not be lost. The towfish is small and light and may be manually deployed and operated by a single person from very small boats thus making it ideal for inshore and coastal applications.

In common with all Tritech sonar systems, SeaKing sidescans may be connected to a SeaKing SCU surface control and display unit or most PC's. In addition to the display of sidescan data, the system will take position input from DGPS. This information is recorded with the sonar data to allow a "fix" of a target. The customer's own bit map chart may be displayed on the same screen as the sonar data.

All data produced by the subsea towfish is processed within the fish and transmitted to the surface in digital format. All data may be stored on the built-in hard disk drive, in the surface control unit.

The post processing export facility will convert the logged data to XTF and CSV formats for third party software packages.

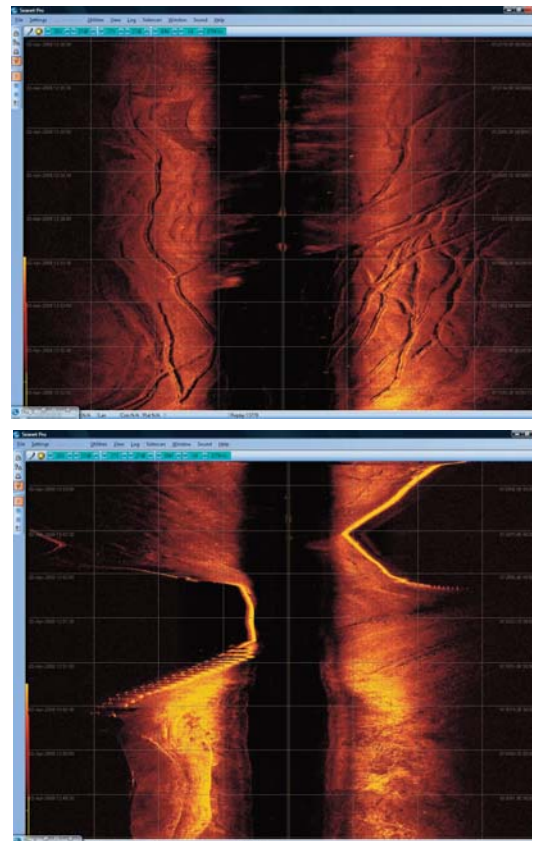

675kHz DST Sidescan images of seabed chains and pier structure

Specifications

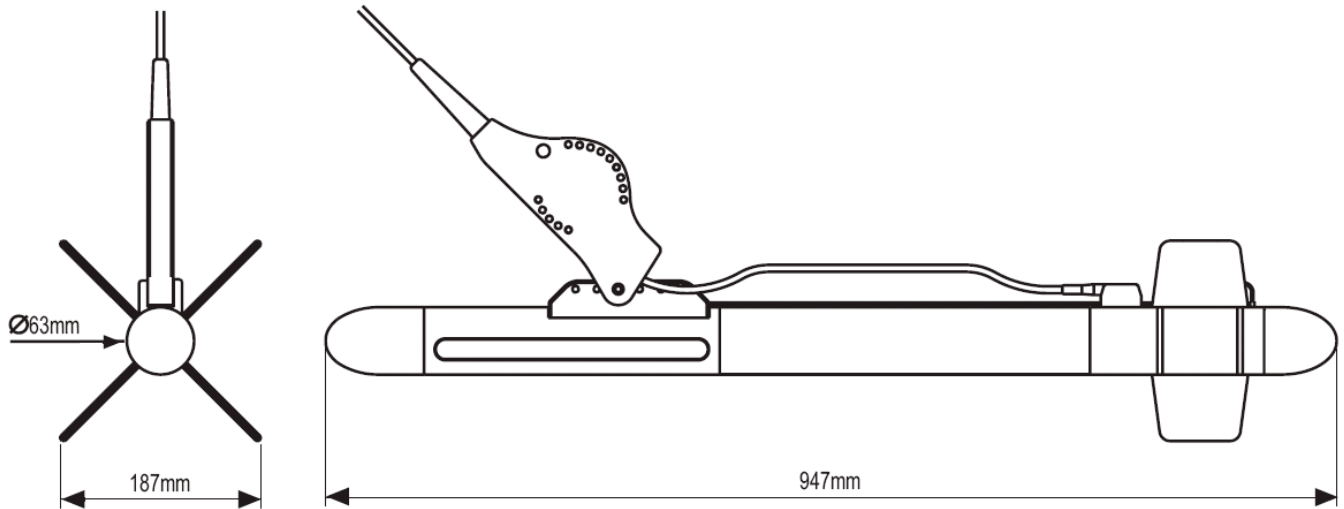

CHIRP Centre Frequency	300kHz	675kHz
Horizontal Beamwidth (-3dB)	1.6°	1°
Vertical Beamwidth (-3dB)	50°	30°
Weight in air	7.0 kg	
Weight in water	4.1 kg	
Power Requirements	24 VDC @ 12VA	
Cable	Standard Kevlar reinforced cable for manual deployment to depths of 40m (6.7mm diameter) Available in lengths of 50, 100 & 150 metres	
Transmitter Source Level	200 dB re 1 uPascal at 1 metre	
Transmitter Pulse Length	400us	200us
Receiver Sensitivity	< 2uVrms	
Gain Control Range	80 dB	
Display Dynamic Range	40 dB (User Configurable)	
Data Resolution	4 - 8 bits (User Configurable)	
Software	Tritech Seanet display and control or low level direct command protocol	
Data Log Format	Proprietary Tritech "V4Log" Exports to XTF, TIFF, GeoTIFF & Google Earth "kMZ" available via converter	
Data Communication	RS485 (twisted pair) Arcnet (twisted pair up to 156 kbaud)	
Printer	Thermal Printer Interface	

All specifications are subject to change in line with Tritech's policy of continual product development.

Ref: EDS-SID-002.11